

Over 55  
years of  
experience



BLANCHER COOKER / COOLER



PEELER WASHER

For more than 55 years, growers and processors have relied on the experienced people of Hughes Equipment Company for processing system solutions.

Our staff's deep knowledge of the food processing sector leads to innovative solutions that raise productivity and efficiency —giving processors greater access to the fast-growing prepared and ready-to-eat foods market.

HUGHES EQUIPMENT COMPANY  
WWW.HUGHESEQUIPMENT.COM  
866-535-9303 OR +1-920-623-2000  
COLUMBUS, WISCONSIN, 53925 USA

Hughes  
Equipment Company International



## Custom Solutions in Food Preparation for Ready-to-Eat Meals

GAIN THE EFFICIENCIES AND OUTPUT OF A HUGHES INTEGRATED SYSTEM FOR CONTINUOUS PROCESSING FOR READY-TO-EAT FOODS.



COMPLETE CONTINUOUS PROCESS LINES FOR PREPARED FOODS





*We're ready for you!*

**For ready-to-eat food preparation, Hughes is a guaranteed winner.**

We offer a full line of handling, processing and packaging equipment to bring you up to speed for this rapidly growing market sector. Our continuous process systems dramatically improve production rates and enhance food safety.

**GAIN THE EFFICIENCIES OF A CONTINUOUS LINE**

With a continuous processing line from Hughes, you'll significantly increase output over batch processing, while producing quality prepared foods that retain the fresh appearance, proper texture and great taste consumers demand.

**CUSTOM SOLUTIONS**

Each prepared foods system is unique. The experts at Hughes Equipment Company can work directly with you to design an integrated line. Or we can work directly with your engineering firm to assist in designing a system that will provide the highest productivity.

**EQUIPMENT FOR ANY PREPARED FOOD**

Our continuous systems can include tote dumpers, conveyors, washers, blanchers, coolers, peelers, cutters, mixers, blenders, dewatering systems, fillers, flash freezers, and packaging and wrapping machines.

With food safety in mind, all our equipment is designed for efficiency and thorough sanitization.

**Continuous Cooking/Cooling Solution**

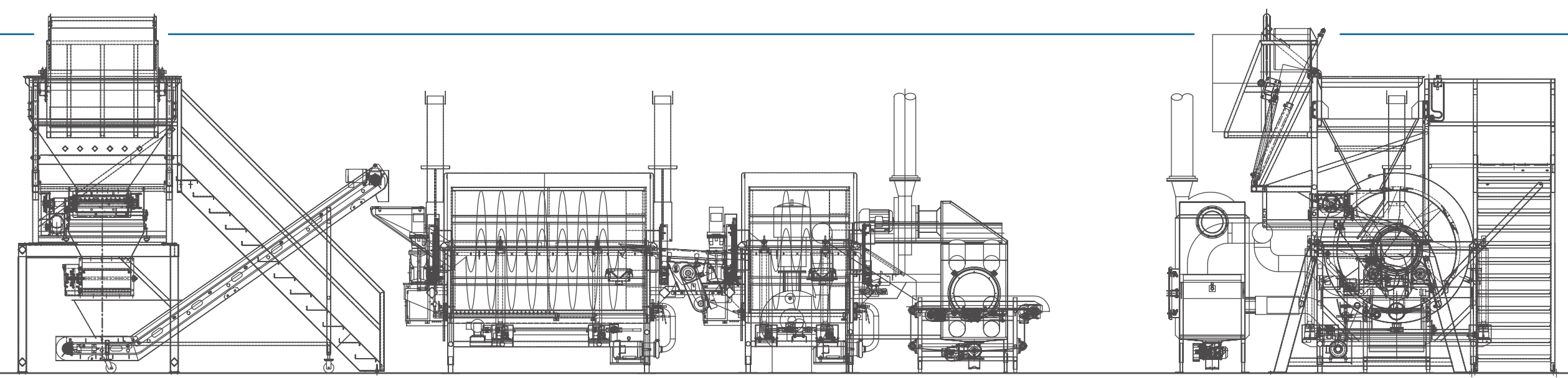

METERING SYSTEM

INCLINE CONVEYOR

60 x 8 BLANCHER

TRANSFER CONVEYOR

60 x 4 COOLER

VACUUM CONVEYOR

SIDE VIEW